

Product Brochure

Anritsu

# MP2100A Series

BERTWave

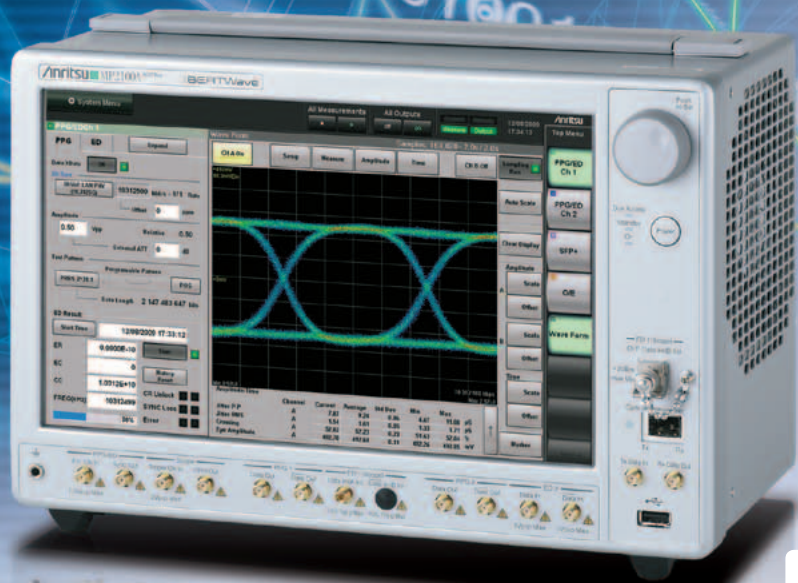

# Slim All-in-One Instrument for BER and Eye-pattern Analysis

## Cuts Measurement Times and Raises Productivity

The rapid spread of the Internet and increases in network transmission capacity are driving development and manufacturing of FTTx and 10-Gbit Ethernet devices. As a result, R&D into high-speed transmission technologies and manufacturing of high-speed devices are both progressing at a fast pace. To assure the integrity of signals passing via these high-speed devices, the Bit Error Rate (BER) and Eye-pattern are measured using a BERT and sampling scope. The all-in-one MP2100A series BERTWave supporting simultaneous BER and Eye-pattern measurements is ideal for both R&D and manufacturing tests because it increases efficiency and cuts measurement costs by eliminating time-consuming setup.

## MP2100A series BERTWave

The MP2100A series BERTWave cuts measurement times and assures signal integrity. Customers can tailor the configuration according to usage.

### MP2100A BERTWave

All-in-one instrument supporting simultaneous BER measurements and Eye-pattern analysis

### MP2101A BERTWave PE

BER tester supporting 125 Mbit/s to 12.5 Gbit/s

### MP2102A BERTWave SS

Eye/Pulse pattern tester supporting high-speed mask tests

MP2100A BERTWave

BERT

Eye/Pulse Scope

MP2101A BERTWave PE

BERT

MP2102A BERTWave SS

Eye/Pulse Scope

## Cuts Measurement Times

All-in-one BER and Eye-pattern Measurements

High-speed Remote Tests

High-speed Mask Tests

## Various Analysis Functions

Wide Operation Frequency Range

Supports Electrical and Optical Interfaces

Simultaneous 2-channel BER Measurements

Clock Recovery

Signal Integrity Analysis

## Low Equipment and Running Costs

Flexible Measurement

Easy Operability, Flash Disk Drive, and Eco-friendly

# Cuts Measurement Times

## All-in-one BER and Eye-pattern Measurements

Simultaneous BER and Eye/Pulse Scope measurements using an all-in-one tester halve investment costs and cut measurement times. The tracking function supports easy BERT and Eye/Pulse Scope settings.

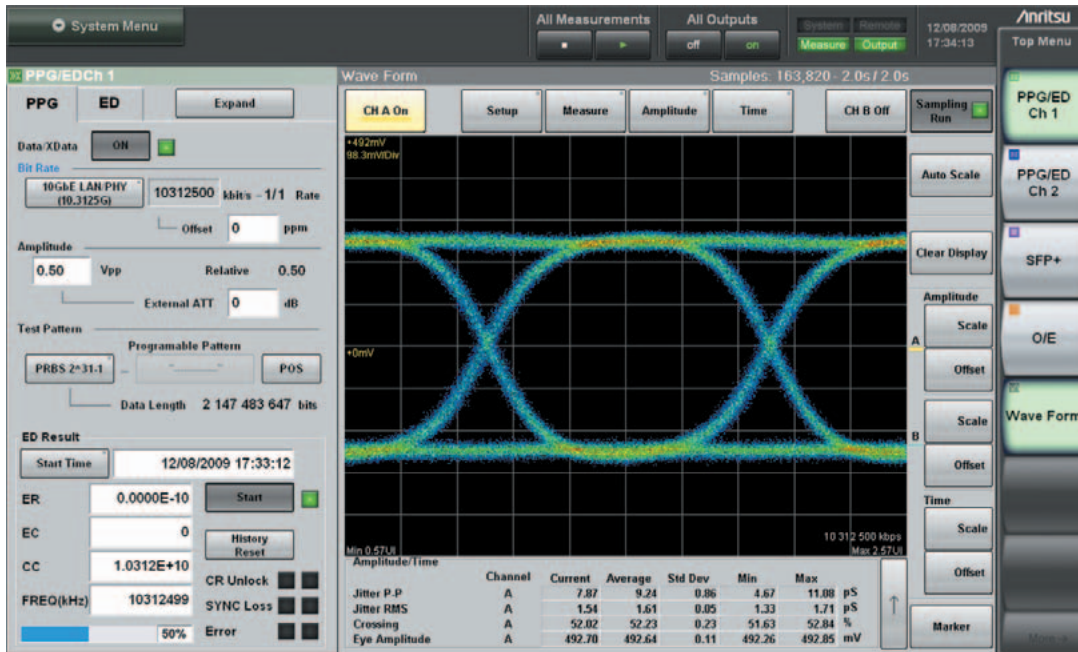

## High-speed Remote Tests

The built-in remote high-speed mode supports mix remote functions for batch processing multiple commands and cuts BER measurement times by 30%\* to 10 ms.

\*: Compared to MP1761C/62C

### • Mix Remote Function:

The mix remote function supports batch sending of the four commands required to set the operation frequency, bit rate, output amplifier, and test pattern, cutting setting times by 75%.

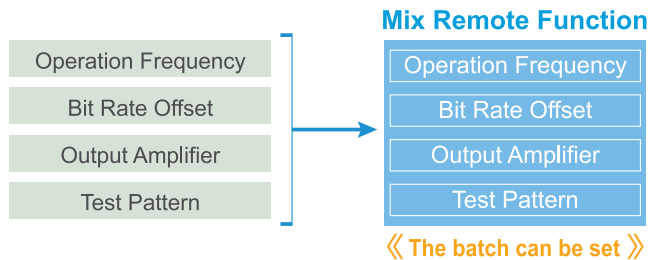

## High-speed Mask Tests

High-speed sampling enabled the acquisition of 100,000 samples in about 1 s. And, it support Automatic Mask Margin test within 1 s. As a result, cutting measurement times.

# Various Analysis Functions

## Supports Electrical and Optical Interfaces

One MP2100A supports both electrical and optical interfaces for performing simultaneous TRx evaluations of optical modules, cutting measurement times.

## Wide Operation Frequency Range

The BERT function supports bit rate from 125 Mbit/s to 12.5 Gbit/s (with Option-090) for evaluating devices and application supporting STM-1, 10 GFC and etc...

### Support Bit Rate and Application samples (With Option 090)

PPG/ED Operation Bit Rate	Application samples
8 Gbit/s to 12.5 Gbit/s	<ul style="list-style-type: none"> <li>• 8GFC</li> <li>• 10GFC</li> <li>• 10GFC FEC</li> <li>• OTU-2</li> <li>• OTU-2e</li> <li>• 10GbE</li> <li>• 10GbE FEC</li> <li>• OC-192/STM-64</li> <li>• OC-192/STM-64 FEC</li> <li>• OTU-1e</li> </ul>
4 Gbit/s to 6.25 Gbit/s	<ul style="list-style-type: none"> <li>• CPRI/OBSAI</li> <li>• 4GFC</li> </ul>
2 Gbit/s to 3.125 Gbit/s	<ul style="list-style-type: none"> <li>• CPRI/OBSAI</li> <li>• 2GFC</li> <li>• Infiniband</li> <li>• 2GbE</li> <li>• OC-48/STM-16</li> <li>• OTU-1</li> </ul>
1 Gbit/s to 1.5625 Gbit/s	<ul style="list-style-type: none"> <li>• 1GbE</li> <li>• 1GFC</li> </ul>
0.5 Gbit/s to 0.78125 Gbit/s	<ul style="list-style-type: none"> <li>• OC-12/STM-4</li> </ul>
0.25 Gbit/s to 0.39625 Gbit/s	
0.125 Gbit/s to 0.195312 Gbit/s	<ul style="list-style-type: none"> <li>• OC-3/STM-1</li> </ul>

### Support Bit Rate and Application samples (Without Option 090)

PPG Operation Bit Rate	Application samples
8.5 Gbit/s to 11.32 Gbit/s	<ul style="list-style-type: none"> <li>• 8GFC</li> <li>• 10GFC</li> <li>• 10GFC FEC</li> <li>• OTU-2</li> <li>• OTU-2e</li> <li>• 10GbE</li> <li>• 10GbE FEC</li> <li>• OC-192/STM-64</li> <li>• OC-192/STM-64 FEC</li> <li>• OTU-1e</li> </ul>
4.25 Gbit/s to 5.66 Gbit/s	<ul style="list-style-type: none"> <li>• 4GFC</li> </ul>
2.125 Gbit/s to 2.83 Gbit/s	<ul style="list-style-type: none"> <li>• 2GFC</li> <li>• Infiniband</li> <li>• 2GbE</li> <li>• OC-48/STM-16</li> <li>• OTU-1</li> </ul>
1.0625 Gbit/s to 1.415 Gbit/s	<ul style="list-style-type: none"> <li>• 1GbE</li> <li>• 1GFC</li> </ul>
0.53125 Gbit/s to 0.7075 Gbit/s	<ul style="list-style-type: none"> <li>• OC-12/STM-4</li> </ul>
0.265625 Gbit/s to 0.35375 Gbit/s	
0.132812 Gbit/s to 0.176875 Gbit/s	<ul style="list-style-type: none"> <li>• OC-3/STM-1</li> </ul>

ED Operation Bit Rate	Application samples
8.5 Gbit/s to 11.32 Gbit/s	<ul style="list-style-type: none"> <li>• 8GFC</li> <li>• 10GFC</li> <li>• 10GFC FEC</li> <li>• OC-192/STM-64</li> <li>• OC-192/STM-64 FEC</li> </ul>
4.25 Gbit/s to 5.66 Gbit/s	<ul style="list-style-type: none"> <li>• 4GFC</li> </ul>

## Simultaneous 2-channel BER Measurements

Expansion of the BERT to 2 channels supports easy simultaneous TRx measurements, crosstalk tests and confirmation of adjacent lane interference.

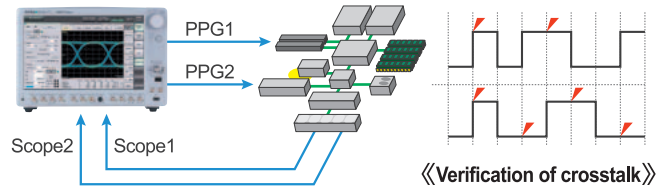

## Insertion / Omission

This can check how signal is involved.

- Insertion: Change of 0→1
- Omission: Change of 1→0

## Clock Recovery

### ED Clock Recovery Function (Standard):

This is for inputting data signals and performing BER analysis without an external clock.

- 4 Gbit/s to 6.25 Gbit/s, 8 Gbit/s to 12.5 Gbit/s
- This have been using the trigger of Scope.

### Eye/Pulse Pattern Clock Recovery Function (Option-055):

- 8.5 GHz to 12.5 GHz, 0.1 GHz to 2.7 GHz
- This supports evaluation of characteristics of long-distance transmissions and equipment without clock output.

## Signal Integrity Analysis

The Eye/Pulse Scope supporting DC to 25 GHz offers signal integrity analysis using a variety of applications.

## Time and Amplifier Tests

These tests supports measurement of 0 and 1 levels, SNR, Eye crosspoint ratio, Eye amplification, Eye height, Eye width, Jitter p-p values, Jitter RMS, Extinction ratio, Rise and Fall times, Duty cycle distortion, and Average power and OMA.

In addition, the high-accuracy extinction ratio measurements close to ideal values are perfect for confirming the characteristics of optical modules.

Amplitude/Time	Channel	Current	Average	Std Dev	Min	Max
Jitter P-P	A	44.94	44.52	0.48	43.87	45.29 pS
Jitter RMS	A	5.97	5.98	0.01	5.97	6.01 pS
Crossing	A	53.42	53.20	0.19	53.03	53.42 %
Eye Amplitude	A	101.51	101.44	0.04	101.36	101.51 mV



## Ideal Extinction Ratio Measurements

### High-accuracy Extinction Ratio Measurements Close to Ideal Values

#### 1. Ideal Bessel filters

Bessel filters with the ideal frequency characteristics support high-accuracy extinction ratio measurement results.

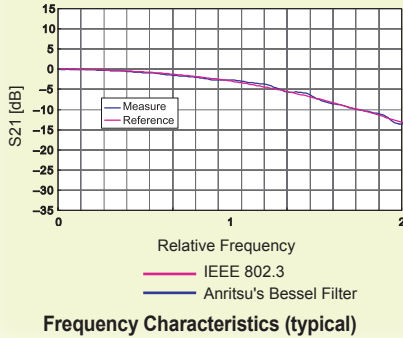

#### 2. High-accuracy results close to true value

Calibration using the reference light source holds error to less than  $\pm 0.05$  dB (typ.).

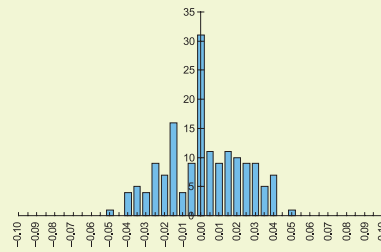

#### 3. Correction function

Correction of the measured extinction ratio assures correlation with other instruments.

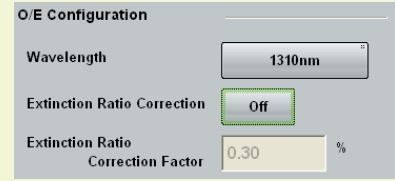

Correction Value Input Display

## Eye Mask/Mask Margin Tests

Eye Mask and Mask Margin tests confirm product margin against standards to improve yield.

- Automatic measurement within 1 s
- Supporting real time Mask Margin test

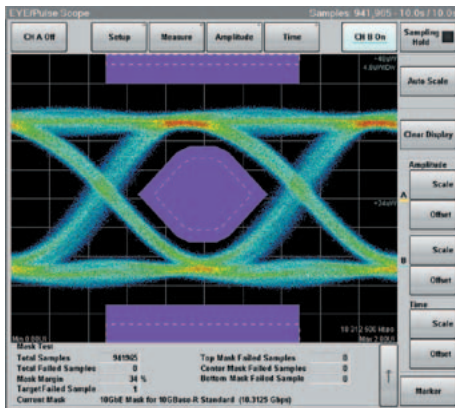

## Change Specified Mask Area

The specified mask area for the target application or user mask can be changed. Consequently, positions in the open Eye where the mask margin is maximum and minimum can be evaluated.

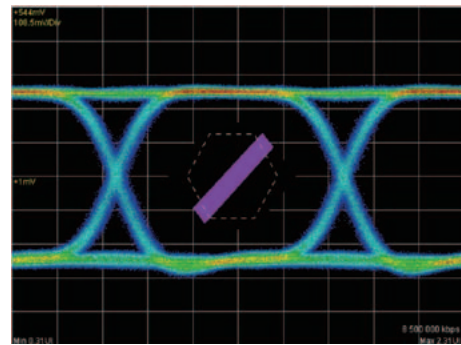

Mask Area Restriction On (45 degrees, 0.1UI)

## Mask Adjust

The Eye mask area can be adjusted either automatically or manually. As a result, the waveform mask can be measured without restrictions on the time axis.

\*: Can set when Align Method is User Defined.

# Low Cost and Eco-friendly Design

## Histogram

Measuring averages, standard deviation and scatter of data in a specified area supports waveform data component analysis and troubleshooting.

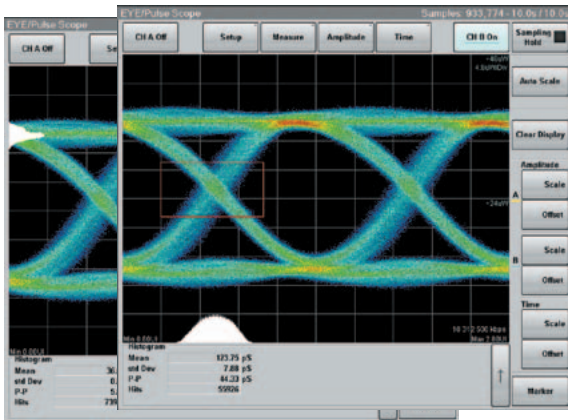

## Reference Trace Function

This function saves measured waveforms to compare saved data with waveforms being measured.

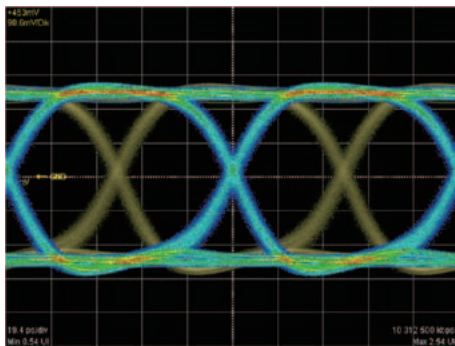

## Skew Function

The built-in skew function moves the waveform on the time axis to adjust the waveform position. Therefore, this function can adjust the phase between channels of differential signal.

## Flexible Measurements

Equipment costs are cut by choosing a custom configuration from the BERTWave, BERTWave PE, and BERTWave SS range of tailored measurement solutions.

- BERTWave : BER and Eye/Pulse measurements
- BERTWave PE : BER measurement
- BERTWave SS : Eye/Pulse measurement

## Easy Operability, Flash Disk Drive, and Eco-design

### Improved Operability

- PPG/ED simple design
- 12.1-inch display
- Intuitive GUI with touch panel

### High Reliability

- The flash drive makes hard-disk crashes a thing of the past.

### Eco-design

- 18-cm deep compact design
- Dimensions: 341 (W)  $\times$  221 (H)  $\times$  180 (D) mm
- Lightweight (7 kg Max.)
- Low power consumption (300 VA Max.)

# MP2100A Series BERTWave

## MP2100A BERTWave

### Optical Module Evaluations

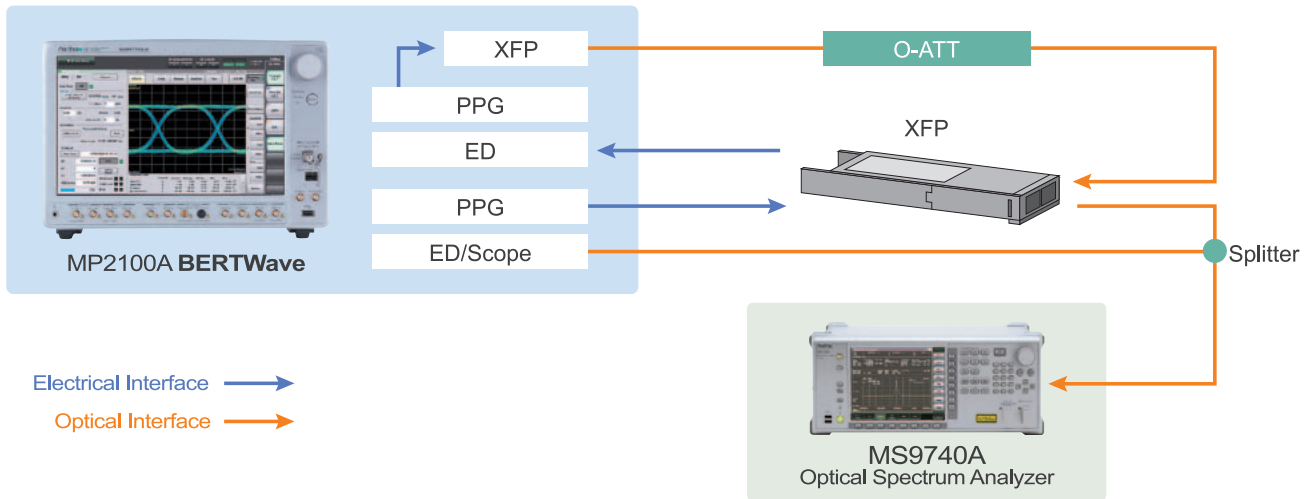

### Cuts Measurement Times

Simultaneous BER and Eye/Pulse Scope measurements using the all-in-one tester halve investment costs and cut measurement times. Use with the MP2100A BERTWave and MS9740A Optical Spectrum Analyzer cuts optical module measurement times.

- **Simultaneous TRx Measurements**

One MP2100A supports both electrical and optical interfaces for performing simultaneous TRx evaluations of optical modules, cutting measurement times.

- **High-speed Remote Tests**

The built-in remote high-speed mode supports mixed remote functions for batch processing multiple commands and cuts BER measurement times by 30% to 10 ms.

- **High-speed Mask Tests**

High-speed sampling supports fast mask tests in about 12 s\*, cutting measurement times.

\*: Typical value when capturing 1 x 10<sup>6</sup> samples at bit rate of 10.3125 Gbit/s with PRBS31 test pattern, back-to-back

### Optical Transceiver Measurement Items

Measurement Items		MP2100A BERTWave	MS9740A Optical Spectrum Analyzer
Tx	Data Rate Tolerance	√	
	Center Wavelength		√
	Side Mode Suppression Ratio		√
	Average Optical Output Power (Min./Max.)	√	√
	Extinction Ratio	√	
	Mask Test	√	
Rx	Input Sensitivity (10 <sup>-12</sup> )	√*	

\*: Programmable optical attenuator is needed.

## MP2100A BERTWave/MP2101A BERTWave PE

### Active Optical Cable Evaluation

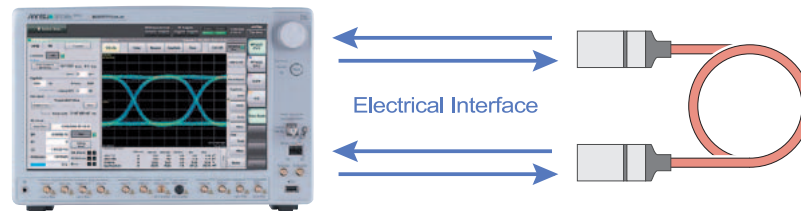

### Simultaneous TRx Measurements and Crosstalk Tests

Expansion of the MP2101A BERTWave PE to a 2-channel BERT supports simultaneous TRx measurements and crosstalk tests for high-speed, multilane active optical cables to help reduce crosstalk. Moreover, selecting the MP2100A BERTWave supports simultaneous Eye-pattern analysis to further improve manufacturing yields.

- **Simultaneous 2-channel BER Measurements**

Expansion of the BERT to 2 channels supports easy simultaneous TRx measurements and confirms crosstalk tests.

- **All-in-one BER and Eye-pattern\***

Simultaneous BER measurements and Eye-pattern analysis using an all-in-one tester does not require a separate BERT and sampling scope, halving equipment costs.

- **Wide Operating Frequency Range\***

The BERT function supports bit rate from 125 Mbit/s to 12.5 Gbit/s (with Option-090) for evaluating devices and application supporting STM-1, 10 GFC and etc...

\*: The MP2100A BERTWave supports Eye-pattern analysis and Eye mask tests.

## MP2102A BERTWave SS

### Evaluation of Transmission Equipment Physical Layer

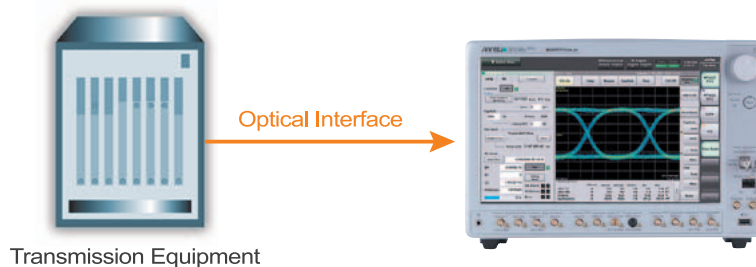

### Physical Layer Evaluation

The MP2102A BERTWave SS clock recovery function eliminates the need for a trigger source when evaluating optical output characteristics, and the full range of mask patterns makes the MP2102A ideal for both evaluating the physical layer of equipment supporting various 2G, 4G, and 8GFC applications, and for testing optical transceivers at acceptance inspection.

- **Clock Recovery**

The Eye/Pulse pattern Clock recovery (Option-055) function supports rates of 8.5 GHz to 12.5 GHz and 0.1 GHz to 2.7 GHz to perform mask tests for most applications.

- **High-speed Mask Tests**

High-speed sampling supports fast mask tests in about 12 s\*, cutting measurement times.

\*: Typical value when capturing  $1 \times 10^6$  samples at bit rate of 10.3125 Gbit/s with PRBS31 test pattern, back-to-back



# MP2100A Series BERTWave Composition

## Block Diagram

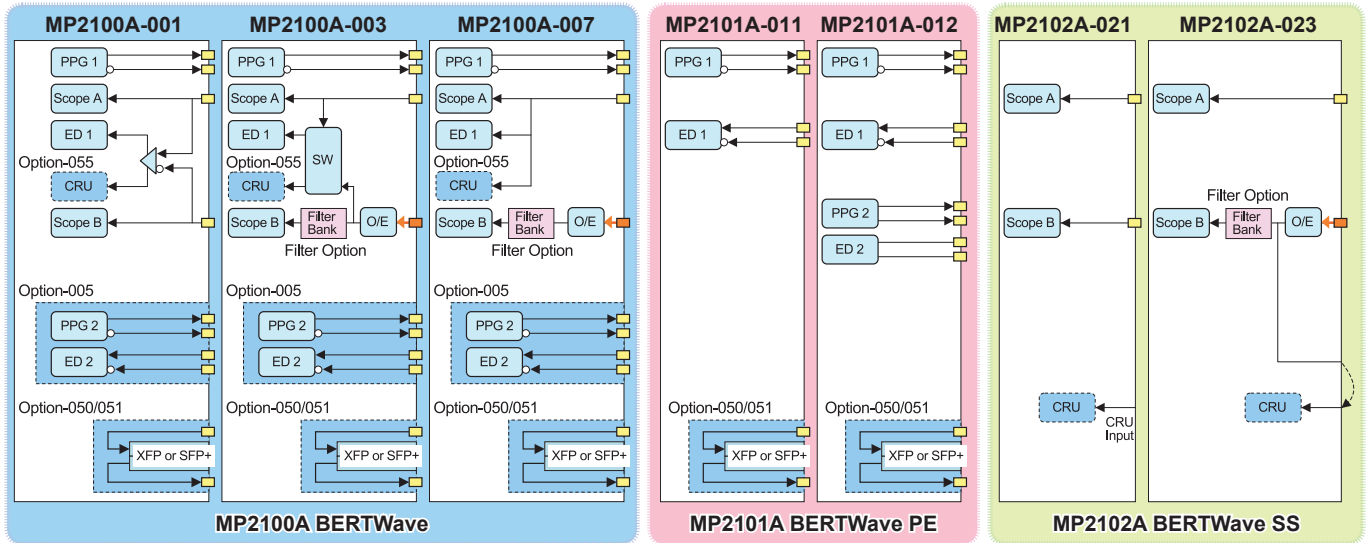

## Interface List

Interface	MP2100A BERTWave		MP2101A BERTWave PE		MP2102A BERTWave SS	
	MP2100A-001	MP2100A-003/007	MP2101A-011	MP2101A-012	MP2102A-021	MP2102A-023
2 Output (Electrical Data1, xData1)	√	√	√	√		
2 Input (Electrical Data1/Scope1, Electrical xData1/Scope2)	√				√	
2 Input (Electrical Data1/Scope1, Optical Data2/Scope2)		√				
2 Input (Electrical Data1, xData1)			√	√		
2 Input (Electrical Scope1, Scope2)					√	
2 Input (Electrical Scope1, Optical Scope2)						√
Additional Interface	2 Output (Electrical Data1, xData1)	√*1	√*1	√		
	2 Input (Electrical Data1, xData1)	√*1	√*1	√		
	XFP Slot	√*2	√*2	√*2	√*2	
	SFP+ Slot	√*3	√*3	√*3	√*3	

## Function List

Interface	MP2100A BERTWave		MP2101A BERTWave PE		MP2102A BERTWave SS	
	MP2100A-001	MP2100A-003/007	MP2101A-011	MP2101A-012	MP2102A-021	MP2102A-023
Crosstalk tests	√*1	√*1		√		
Optical Module Simultaneous TRx measurements (XFP)		√*1, *4				
1ch BER measurement	√	√	√	√		
2ch BER measurement	√*1	√*1		√		
Electrical integrity of signals tests						
- Time and Amplitude Tests	√	√			√	√
- Histogram Test						
- Eye Mask/Mask Margin Tests						
Optical integrity of signals tests						
- Time and Amplitude Tests		√				√
- Histogram Test						
- Eye Mask/Mask Margin Tests						

- \*1: Option-005 Selected
- \*2: Option-050 Selected
- \*3: Option-051 Selected
- \*4: Option-050 or Option-051 Selected

# Selection Guide

## Selection Guide

### BERTWave

Model Number	Model Name	Note
MP2100A	BERTWave	BERT + Eye/Pulse Scope
MP2100A -001	Dual Electrical Receiver	Must select one of those
MP2100A -003	Optical/Single-ended Electrical Receiver	
MP2100A -007	1ch Electrical BERT and Optical/Single-ended Electrical Scope	
MP2100A -005	Extended PPG/ED Channel	
MP2100A -030	GPIB	
MP2100A -037	FC Connector	Option-003/007 is required Must select one of those
MP2100A -038	ST Connector	
MP2100A -039	DIN 47256 Connector	
MP2100A -040	SC Connector	
MP2100A -050	XFP Slot	Select no option or one of these
MP2100A -051	SFP+ Slot	
MP2100A -052	Full Rate Clock Output	
MP2100A -055	Clock Recovery for Eye/Pulse Scope	
MP2100A -061	1 High Bit Rate Filter	Option-003/007 is required About of Filter Bank and Filter, refer to "Filter Bank Configuration"
MP2100A -062	2 High Bit Rate Filter Bank	
MP2100A -063	3 to 4 High Bit Rate Filter Bank	
MP2100A -064	1 to 2 Low Bit Rate Filter Bank	
MP2100A -065	3 to 4 Low Bit Rate Filter Bank	
MP2100A -066	1 High Bit Rate/1 to 2 Low Bit Rate Filter Bank	
MP2100A -067	1 to 2 High Bit Rate/3 to 4 Low Bit Rate Filter Bank	
MP2100A -068	2 to 3 High Bit Rate/1 to 2 Low Bit Rate Filter Bank	
MP2100A -069	3 High Bit Rate/3 Low Bit Rate Filter Bank	
MP2100A -070	LPF for 156M (L)	
MP2100A -071	LPF for 622M (L)	
MP2100A -072	LPF for 1.0G (L)	
MP2100A -073	LPF for 1.2G (L)	
MP2100A -076	LPF for 2.1G (H)	
MP2100A -077	LPF for 2.5G (H)	
MP2100A -078	LPF for 2.6G (H)	
MP2100A -079	LPF for 3.1G (H)	
MP2100A -080	LPF for 4.2G (H)	
MP2100A -081	LPF for 5.0G (H)	
MP2100A -082	LPF for 6.2G (H)	
MP2100A -083	LPF for 8.5G (H)	
MP2100A -084	LPF for 9.9G to 10.3G (H)	
MP2100A -085	LPF for 10.5G to 11.3G (H)	
MP2100A -086	LPF for Multi 10G (H)	
MP2100A -090	Bit rate Extension for PPG/ED	
MP2100A -091	ED High Sensitivity	
MP2100A -130	GPIB Retrofit	
MP2100A -152	Full Rate Clock Output Retrofit	
MP2100A -191	ED High Sensitivity Retrofit	

### BERTWave PE

Model Number	Model Name	Note
MP2101A	BERTWave PE	BERT
MP2101A -011	1CH PGG/ED	Must select one of those
MP2101A -012	2CH PGG/ED	
MP2101A -030	GPIB	Select one of these
MP2101A -050	XFP Slot	Select no option or one of these
MP2101A -051	SFP+ Slot	
MP2101A -052	Full Rate Clock Output	
MP2101A -090	Bit rate Extension for PPG/ED	Select one of these
MP2101A -091	ED High Sensitivity	
MP2101A -130	GPIB Retrofit	
MP2101A -152	Full Rate Clock Output Retrofit	
MP2101A -191	ED High Sensitivity Retrofit	

## BERTWave SS

Model Number	Model Name	Note
MP2102A	BERTWave SS	Eye/Pulse Scope
MP2102A -021	Dual Electrical Receiver	Must select one of those
MP2102A -023	Optical/Single-ended Electrical Receiver	
MP2102A -030	GPIO	Option-023 is required Must select one of those
MP2102A -037	FC Connector	
MP2102A -038	ST Connector	
MP2102A -039	DIN 47256 Connector	
MP2102A -040	SC Connector	
MP2102A -055	Clock Recovery	
MP2102A -061	1 High Bit Rate Filter	Option-023 is required About of Filter Bank and Filter, refer to "Filter Bank Configuration"
MP2102A -062	2 High Bit Rate Filter Bank	
MP2102A -063	3 to 4 High Bit Rate Filter Bank	
MP2102A -064	1 to 2 Low Bit Rate Filter Bank	
MP2102A -065	3 to 4 Low Bit Rate Filter Bank	
MP2102A -066	1 High Bit Rate/1 to 2 Low Bit Rate Filter Bank	
MP2102A -067	1 to 2 High Bit Rate/3 to 4 Low Bit Rate Filter Bank	
MP2102A -068	2 to 3 High Bit Rate/1 to 2 Low Bit Rate Filter Bank	
MP2102A -069	3 High Bit Rate/3 Low Bit Rate Filter Bank	
MP2102A -070	LPF for 156M (L)	
MP2102A -071	LPF for 622M (L)	
MP2102A -072	LPF for 1.0G (L)	
MP2102A -073	LPF for 1.2G (L)	
MP2102A -076	LPF for 2.1G (H)	
MP2102A -077	LPF for 2.5G (H)	
MP2102A -078	LPF for 2.6G (H)	
MP2102A -079	LPF for 3.1G (H)	
MP2102A -080	LPF for 4.2G (H)	
MP2102A -081	LPF for 5.0G (H)	
MP2102A -082	LPF for 6.2G (H)	
MP2102A -083	LPF for 8.5G (H)	
MP2102A -084	LPF for 9.9G to 10.3G (H)	
MP2102A -085	LPF for 10.5G to 11.3G (H)	
MP2102A -086	LPF for Multi 10G (H)	
MP2102A -130	GPIO Retrofit	

## Software for BERTWave series

Model Number	Model Name	Note
MX210001A	Jitter Analysis Software	
MX210002A	Transmission Analysis Software	

## Filter Bank Configuration

Filter Bank		Low Bit Rate LPF				High Bit Rate LPF											
		Option-070	Option-071	Option-072	Option-073	Option-076	Option-077	Option-078	Option-079	Option-080	Option-081	Option-082	Option-083	Option-084	Option-085	Option-086	
		156M (L)	622M (L)	1.0G (L)	1.2G (L)	2.1G (H)	2.5G (H)	2.6G (H)	3.1G (H)	4.2G (H)	5.0G (H)	6.2G (H)	8.5G (H)	9.9G to 10.3G (H)	10.5G to 11.3G (H)	9.9G to 10.7G (H)	
Option-061	1 High Bit Rate Filter	—	—	—	—	Select 1 LPF											
Option-062	2 High Bit Rate Filter Bank	—	—	—	—	Select 2 LPFs											
Option-063	3 to 4 High Bit Rate Filter Bank	—	—	—	—	Select 3 to 4 LPFs											
Option-064	1 to 2 Low Bit Rate Filter Bank	Select 1 to 2 LPFs				—	—	—	—	—	—	—	—	—	—	—	—
Option-065	3 to 4 Low Bit Rate Filter Bank	Select 3 to 4 LPFs				—	—	—	—	—	—	—	—	—	—	—	—
Option-066	1 High Bit Rate/1 to 2 Low Bit Rate Filter Bank	Select 1 to 2 LPFs				Select 1 LPF											
Option-067	1 to 2 High Bit Rate/3 to 4 Low Bit Rate Filter Bank	Select 3 to 4 LPFs				Select 1 to 2 LPFs											
Option-068	2 to 3 High Bit Rate/1 to 2 Low Bit Rate Filter Bank	Select 1 to 2 LPFs				Select 2 to 3 LPFs											
Option-069	3 High Bit Rate/3 Low Bit Rate Filter Bank	Select 3 LPFs				Select 3 LPFs											

# Key Layout

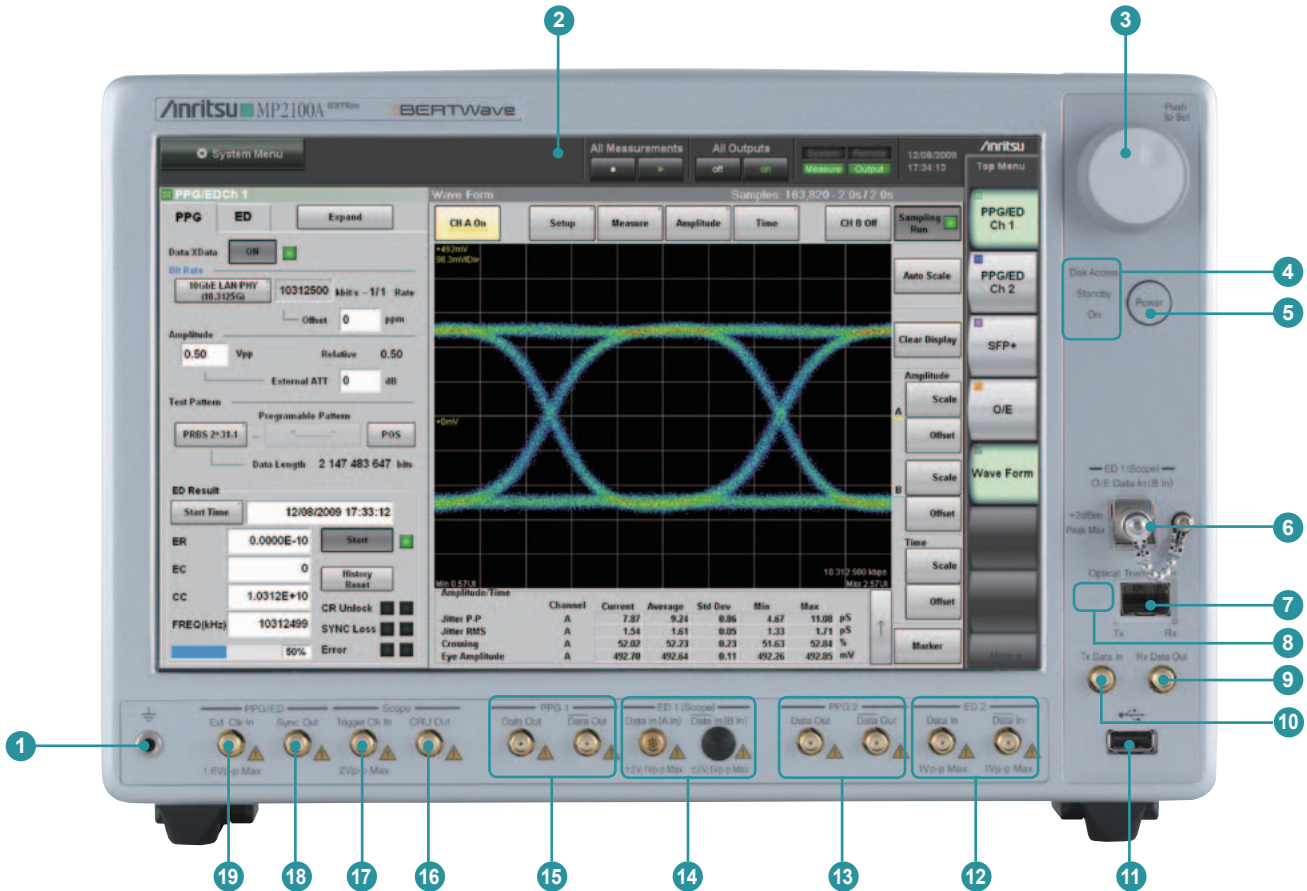

- 1 Ground Terminal**  
Connects antistatic wrist strap
- 2 Display**  
12.1-inch touch panel
- 3 Rotary Knob**  
Changes set value
- 4 Disk Access, Standby and Power Lamps**
- 5 Power Switch**
- 6 Optical Input Connector**  
Supported by MP2100A-003 and MP2102A-023
- 7 Optical Transceiver Slot**  
Supports XFP modules when MP2100A/MP2101A-050 selected as well as SFP + module when MP2100A/MP2101A-051 selected
- 8 Optical Output Display Lamp**  
When MP2100A/MP2101A-050 or MP2100A/MP2101A-051 selected
- 9 Optical Transceiver Received Signal Output Terminal**  
When MP2100A/MP2101A-050 or MP2100A/MP2101A-051 selected
- 10 Optical Transceiver Transmitted Signal Input Terminal**  
When MP2100A/MP2101A-050 or MP2100A/MP2101A-051 selected
- 11 USB Connector**
- 12 Error Detector CH2 Input Terminal**  
When MP2100A-005 or MP2101A-012 selected
- 13 Pulse Pattern Generator CH2 Output Terminal**  
When MP2100A-005 or MP2101A-012 selected
- 14 Error Detector CH1/Eye/Pulse Scope Input Terminal**  
A (in) and B (in) supported when MP2100A-001, MP2101A-011/012, or MP2102A-021 selected.  
A (in) supported when MP2100A-003 or MP2102A-023 selected
- 15 Pulse Pattern Generator CH1 Output Terminal**  
When MP2100A or MP2101A selected
- 16 Clock Recovery Unit Output Terminal**  
When MP2100A-055 or MP2102A-055 selected
- 17 Eye/Pulse Scope Trigger Input Terminal**  
When MP2100A or MP2102A selected
- 18 Synchronized Pulse Output Terminal**  
When MP2100A or MP2101A selected
- 19 Clock Input Terminal**  
When MP2100A or MP2101A selected





Rear

- 20 **10 MHz Clock Input**  
When MP2100A or MP2101A selected
- 21 **GPIB Connector**  
When MP2100A/MP2101A/MP2102A-030 selected
- 22 **Inlet**

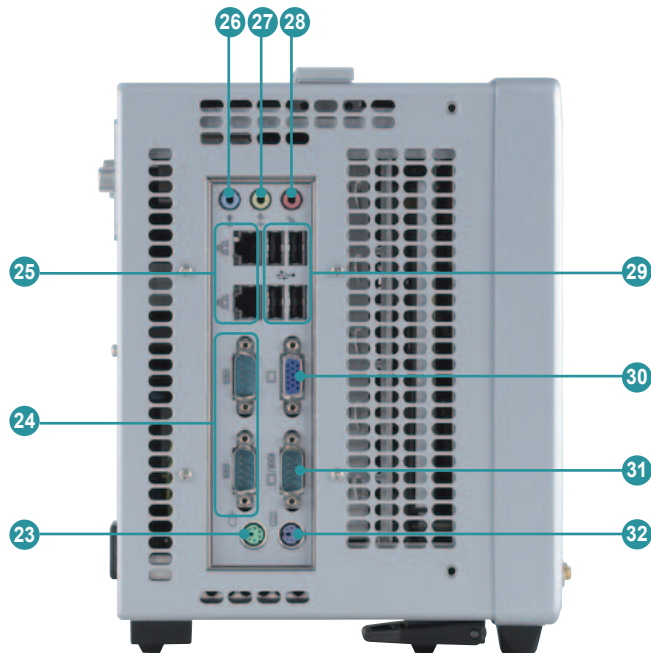

Left side

- 23 **PS2 Mouse Port**
- 24 **Serial Interface**
- 25 **Ethernet Port**
- 26 **Line Input**
- 27 **Line Output**
- 28 **Microphone Input**
- 29 **USB Port**
- 30 **Monitor Output (15 pins)**
- 31 **Monitor Output (9 pins)/Serial Interface**
- 32 **PS2 Keyboard Port**

# Specifications

## MP2100A, MP2101A, MP2102A Common

Input Device	Rotary Encoder, Touch Panel, Power Switch
Liquid-crystal Display	12.1 inch WXGA (1280 × 800)
Remote Interface	Ethernet, GPIB (Option-030)
Circumjacent Connection	VGA Output (SVGA), USB (5ports, Revision 2.0), Ethernet (2ports, 10/100/1000 BASE-T)
OS	Windows embedded standard 2009 (based on Windows XP SP3)
Internal Memory	Flash memory 8 GB (min.)
Power Supply	100 V(ac) to 120 V(ac)/200 V(ac) to 240 V(ac) (100 V/200 V is unnecessary change.), 50 Hz/60 Hz
Power Consumption	300 VA (max.)
Temperature Range	Operating: +5° to +40° C Storage: -20° to +60° C
Dimensions	341 (W) × 221.5 (H) × 180 (D) mm (Exclusive of surface projection)
Mass	7 kg (max.) (With MP2100A-003 installing, Not contain other options)
EMC	EN61326-1, EN61000-3-2
LVD	EN61010-1

## BERT

### • Common

External 10 MHz Input Connector	Amplitude: 0.7 Vp-p to 2 Vp-p, AC coupled Connector: BNC connector, 50 Ω														
External Ref Clock Input	External 1/16 Clock Input Amplitude: 0.2 Vp-p to 1.5 Vp-p, AC coupled Connector: SMA connector, 50 Ω														
Sync. Output	Output Level: $V_{OL}$ : -0.5 V to -0.3 V, $V_{OH}$ : -0.1 V to 0 V, 0.4 Vp-p (typ.) Connector: SMA connector, 50 Ω														
	<table border="1"> <thead> <tr> <th>Bit Rate</th> <th>Frequency Dividing Rate</th> </tr> </thead> <tbody> <tr> <td>8.5G to 11.32G</td> <td>1/8 PPG Clock, 1/16 PPG Clock, 1/64 PPG Clock, PPG Pattern Sync., 1/16 ED Clock</td> </tr> <tr> <td>1/2 Rate</td> <td>1/4 PPG Clock, 1/16 PPG Clock, 1/64 PPG Clock, PPG Pattern Sync., 1/4 ED Clock, 1/16 ED Clock</td> </tr> <tr> <td>1/4 Rate</td> <td>1/2 PPG Clock, 1/16 PPG Clock, PPG Pattern Sync.</td> </tr> <tr> <td>1/8 Rate</td> <td>1/1 PPG Clock, PPG Pattern Sync.</td> </tr> <tr> <td>1/16 Rate</td> <td>1/1 PPG Clock, PPG Pattern Sync.</td> </tr> <tr> <td>1/64 Rate</td> <td>1/1 PPG Clock, PPG Pattern Sync.</td> </tr> </tbody> </table>	Bit Rate	Frequency Dividing Rate	8.5G to 11.32G	1/8 PPG Clock, 1/16 PPG Clock, 1/64 PPG Clock, PPG Pattern Sync., 1/16 ED Clock	1/2 Rate	1/4 PPG Clock, 1/16 PPG Clock, 1/64 PPG Clock, PPG Pattern Sync., 1/4 ED Clock, 1/16 ED Clock	1/4 Rate	1/2 PPG Clock, 1/16 PPG Clock, PPG Pattern Sync.	1/8 Rate	1/1 PPG Clock, PPG Pattern Sync.	1/16 Rate	1/1 PPG Clock, PPG Pattern Sync.	1/64 Rate	1/1 PPG Clock, PPG Pattern Sync.
	Bit Rate	Frequency Dividing Rate													
	8.5G to 11.32G	1/8 PPG Clock, 1/16 PPG Clock, 1/64 PPG Clock, PPG Pattern Sync., 1/16 ED Clock													
	1/2 Rate	1/4 PPG Clock, 1/16 PPG Clock, 1/64 PPG Clock, PPG Pattern Sync., 1/4 ED Clock, 1/16 ED Clock													
	1/4 Rate	1/2 PPG Clock, 1/16 PPG Clock, PPG Pattern Sync.													
	1/8 Rate	1/1 PPG Clock, PPG Pattern Sync.													
1/16 Rate	1/1 PPG Clock, PPG Pattern Sync.														
1/64 Rate	1/1 PPG Clock, PPG Pattern Sync.														

### • PPG

Operation Bit Rate	With MP2100A/MP2101A-090	Without MP2100A/MP2101A-090
	Variable bit-rate range (1 kbit/s step) 8 Gbit/s to 12.5 Gbit/s 1/N bit-rate operation range N=2: 4 Gbit/s to 6.25 Gbit/s N=4: 2 Gbit/s to 3.125 Gbit/s N=8: 1 Gbit/s to 1.5625 Gbit/s N=16: 500 Mbit/s to 781.25 Mbit/s N=32: 250 Mbit/s to 390.625 Mbit/s N=64: 125 Mbit/s to 195.312 Mbit/s	Variable bit-rate range (1 kbit/s step) 8.5 Gbit/s to 11.32 Gbit/s 1/N bit-rate operation range N=2: 4.25 Gbit/s to 5.66 Gbit/s N=4: 2.125 Gbit/s to 2.83 Gbit/s N=8: 1.0625 Gbit/s to 1.415 Gbit/s N=16: 531.25 Mbit/s to 707.5 Mbit/s N=32: 265.625 Mbit/s to 353.75 Mbit/s N=64: 132.813 Mbit/s to 176.875 Mbit/s
Internal Reference Clock Accuracy	±10 ppm Offset Variability: ±100 ppm, 1 ppm step	
Data Output	Data, xData Amplitude: Variable 0.1 Vp-p to 0.8 Vp-p, 10 mV step, AC coupled Tr/Tf: 25 ps (20 to 80%, typ.) Output Jitter: 3 ps rms (typ.) Connector: SMA connector, 50 Ω	
Test Pattern	PRBS: $2^7 - 1$ , $2^9 - 1$ , $2^{15} - 1$ , $2^{23} - 1$ , $2^{31} - 1$ (Invert ON/OFF) User Data: 1.3 Mbits (Editable Text File, Presence Sample File)	
Error Addition	Repeat, Single	

• ED

Operation Bit Rate	With MP2100A/MP2101A-090	Without MP2100A/MP2101A-090
	Variable bit-rate range (1 kbit/s step) 8 Gbit/s to 12.5 Gbit/s  1/N bit-rate operation range* N=2: 4 Gbit/s to 6.25 Gbit/s N=4: 2 Gbit/s to 3.125 Gbit/s N=8: 1 Gbit/s to 1.5625 Gbit/s N=16: 500 Mbit/s to 781.25 Mbit/s N=32: 250 Mbit/s to 390.625 Mbit/s N=64: 125 Mbit/s to 195.3125 Mbit/s	Variable bit-rate range (1 kbit/s step) 8.5 Gbit/s to 11.32 Gbit/s 4.25 Gbit/s to 5.66 Gbit/s
Offset Capacity	±100 ppm	
Electrical Data Input	Input Number: Data, xData, Single-ended or Differential (With MP2100A-001, MP2101A-011, MP2101A-012) Data, Single (With MP2100A-003) Input Format: NRZ, Mark Ratio 50% Threshold: -0.085 V to +0.085 V, 1 mV step Consecutive Identical Digit Tolerance: 72 bits (min.) Connector MP2100A: K connector MP2101A: SMA connector	
	With MP2100A/MP2101A-090	Without MP2100A/MP2101A-090
	0.1 Vp-p to 0.8 Vp-p, AC coupled : 8.0 Gbit/s to 11.32 Gbit/s and 1/N bit rate above (10.3125 Gbit/s, single-ended 0.1 Vp-p, loopback, PRBS31, mark ratio 1/2, 20° to 30°C, BER <1E-12)  0.25 Vp-p to 0.8 Vp-p, AC coupled: 11.320001 Gbit/s to 12.5 Gbit/s and 1/N bit rate above (12.288 Gbit/s, single-ended 0.25 Vp-p, loopback, PRBS31, mark ratio 1/2, 20° to 30°C, BER <1E-12)	0.1 Vp-p to 0.8 Vp-p, AC coupled: 8.5 Gbit/s to 11.32 Gbit/s and 1/N bit rate above (10.3125 Gbit/s, single-ended 0.1 Vp-p, loopback, PRBS31, mark ratio 1/2, 20° to 30°C, BER <1E-12)
Optical Data Input (O/E Input)	Input Number: 1 (With MP2100A-003) Input Format: NRZ, Mark Ratio 50% Optical Sensitivity: -9 dBm (typ.) Another Specification is same Optical Data Input of Eye/Pulse Scope (O/E Input) specification.	
Test Pattern	PRBS: 2 <sup>7</sup> - 1, 2 <sup>9</sup> - 1, 2 <sup>15</sup> - 1, 2 <sup>23</sup> - 1, 2 <sup>31</sup> - 1 (Invert ON/OFF) USER Data: 1.3 Mbit/s (Editable Text File, Presence Sample File)	
Measurement	Error Rate: 0.0001E-18 to 1.0000E-00 Error Count: 1.0000E07 to 9.9999E17	

\*: When N is 4 or higher, asynchronous data recovery is used for the ED.  
 In this case, the ED sync. clock cannot be used.

**Eye/Pulse Scope**

Function	Wave Display: Eye Pattern, Pulse Pattern Measurement Function: Time and Amplitude tests, Histogram, Eye Mask/Mask Margin Tests
Sampling Speed	100 k sample/s (typ.)
Trigger Clock Input	Frequency: 0.1 GHz to 12.5 GHz Sensitivity: 100 mVp-p (typ.) Maximum Amplitude: 2 Vp-p Jitter 5 GHz to 12.5 GHz: 0.85 ps rms (typ.) 1 GHz to 5 GHz: 1 ps rms (typ.) 0.1 GHz to 1 GHz: 2 ps rms (typ.) Connector: SMA connector, 50 Ω
Electrical Data Input	Input Number: A in, B in (A in is Data of BERT and B in is xData of BERT is use the common port) (With MP2100A-001, MP2102A-021) Input Number: A in (A in is Data of BERT is use the common port) (With MP2100A-003, MP2102A-023) Bandwidth (-3 dB): DC to 20 GHz (min.), DC to 25 GHz (typ.) Maximum Input: ±2 V Input Range: ±500 mV offset (min.) ±400 mV dynamic range (min.)

Optical Data Input (O/E Input)		<p>Input Number: 1 (B in)  Fiber: 62.5 <math>\mu\text{m}</math>, Multimode, accepts single mode  Wavelength: 750 nm to 1650 nm  Bandwidth: DC to 9 GHz (typ., Unfiltered, -3 dB electrical)  Responsively: 0.25 A/W (850 nm, typ.), 0.475 A/W (1310 nm, typ.), 0.45 A/W (1550 nm, typ.)  Conversion Gain: 112.5 V/W (850 nm, typ.), 210 V/W (1310 nm, typ.), 200 V/W (1550 nm, typ.)  Optical Noise: 15 <math>\mu\text{W}</math> (typ.)  Optical Sensitivity</p> <table border="1"> <tr> <td colspan="2">MP2100A:</td> <td>Option-003</td> <td>Option-007</td> </tr> <tr> <td rowspan="3">Filter Option</td> <td>Without Filter</td> <td>-12 dBm</td> <td>-15 dBm</td> </tr> <tr> <td>With Option-086</td> <td>-11 dBm</td> <td>-14 dBm</td> </tr> <tr> <td>With Filter (except Option-086)</td> <td>-9 dBm</td> <td>-12 dBm</td> </tr> <tr> <td colspan="2">MP2102A:</td> <td>—</td> <td>Option-055</td> </tr> <tr> <td rowspan="3">Filter Option</td> <td>Without Filter</td> <td>-15 dBm</td> <td>-12 dBm</td> </tr> <tr> <td>With Option-086</td> <td>-14 dBm</td> <td>-11 dBm</td> </tr> <tr> <td>With Filter (except Option-086)</td> <td>-12 dBm</td> <td>-9 dBm</td> </tr> </table> <p>Maximum Input Power: -1 dBm or 794 <math>\mu\text{W}</math> (average)  +2 dBm or 1.58 mW (peak)  Absolute Maximum Ratings: +5 dBm or 3.16 mW (peak)  Optical Return Loss: -30 dB (typ.)  Connector: Select one of these Options  Option-037 FC connector  Option-038 ST connector  Option-039 DIN 47256 connector  Option-040 SC connector</p>	MP2100A:		Option-003	Option-007	Filter Option	Without Filter	-12 dBm	-15 dBm	With Option-086	-11 dBm	-14 dBm	With Filter (except Option-086)	-9 dBm	-12 dBm	MP2102A:		—	Option-055	Filter Option	Without Filter	-15 dBm	-12 dBm	With Option-086	-14 dBm	-11 dBm	With Filter (except Option-086)	-12 dBm	-9 dBm
		MP2100A:		Option-003	Option-007																									
Filter Option	Without Filter	-12 dBm	-15 dBm																											
	With Option-086	-11 dBm	-14 dBm																											
	With Filter (except Option-086)	-9 dBm	-12 dBm																											
MP2102A:		—	Option-055																											
Filter Option	Without Filter	-15 dBm	-12 dBm																											
	With Option-086	-14 dBm	-11 dBm																											
	With Filter (except Option-086)	-12 dBm	-9 dBm																											
<p>Connector: SMA connector (Jack), 50 <math>\Omega</math> (AC coupled)  Amplitude: 100 mVp-p (typ.)  Maximum Amplitude: 2 Vp-p: input before damage</p>																														
Clock Recovery (Option-055)	CRU Input	<p>Connector: SMA connector (Jack), 50 <math>\Omega</math> (AC coupled)  Amplitude: 0.5 Vp-p to 1.5 Vp-p</p>																												
	CRU Output	<p>8.5 GHz to 12.5 GHz, 0.1 GHz to 2.7 GHz</p>																												
	Clock Rates	<p>8.5 GHz to 12.5 GHz band: 10 mUI (typ.), 20 mUI (4 MHz loop BW, max.)  0.1 GHz to 2.7 GHz band: 5 mUI (typ.)</p>																												
	Jitter, RMS (additive)	<p>8.5 GHz to 12.5 GHz band: 1, 2, 4, or 8 MHz (Possible to change, typ.)  0.1 GHz to 2.7 GHz band  2488.32 GHz: 200 kHz (typ.)  622 MHz: 50 kHz (typ.)  156 MHz: 20 kHz (typ.)</p>																												
	Loop Bandwidth (typ.)																													
Low Pass Filter (156M) (Option-070)		0.116 GHz (-3 dB cut off typical) LPF																												
Low Pass Filter (622M) (Option-071)		0.47 GHz (-3 dB cut off typical) LPF																												
Low Pass Filter (1.0G) (Option-072)		0.80 GHz (-3 dB cut off typical) LPF																												
Low Pass Filter (1.2G) (Option-073)		0.94 GHz (-3 dB cut off typical) LPF																												
Low Pass Filter (2.1G) (Option-076)		1.6 GHz (-3 dB cut off typical) LPF																												
Low Pass Filter (2.5G) (Option-077)		1.87 GHz (-3 dB cut off typical) LPF																												
Low Pass Filter (2.6G) (Option-078)		2.0 GHz (-3 dB cut off typical) LPF																												
Low Pass Filter (3.1G) (Option-079)		2.37 GHz (-3 dB cut off typical) LPF																												
Low Pass Filter (4.2G) (Option-080)		3.2 GHz (-3 dB cut off typical) LPF																												
Low Pass Filter (5.0G) (Option-081)		3.75 GHz (-3 dB cut off typical) LPF																												
Low Pass Filter (6.2G) (Option-082)		4.61 GHz (-3 dB cut off typical) LPF																												
Low Pass Filter (8.5G) (Option-083)		6.3 GHz (-3 dB cut off typical) LPF																												
Low Pass Filter (9.9G to 10.3G) (Option-084)		7.6 GHz (-3 dB cut off typical) LPF																												
Low Pass Filter (10.5G to 11.3G) (Option-085)		8.2 GHz (-3 dB cut off typical) LPF																												
Low Pass Filter (9.9G to 10.7G) (Option-086)		7.5 GHz (-3 dB cut off typical) LPF																												



## XFP Slot (Option-050)

Tx Data Input	Single-ended data input: 0.2 Vp-p to 0.4 Vp-p Input waveform: NRZ Connector: SMA connector, 50 Ω/GND
Rx Data Output	Single-end output level: 0.1 Vp-p (min.), 1.0 Vp-p (max.) Output waveform: NRZ Connector: SMA connector, 50 Ω/GND
Laser Safety	IEC60825-1: 2007: CLASS 1 21CFR1040.10*

## SFP+ Slot (Option-051)

Tx Data Input	Single-end input level: 0.6 Vp-p to 0.8 Vp-p (G0238A) 0.25 Vp-p to 0.35 Vp-p (G0239A) Input waveform: NRZ Connector: SMA connector, 50 Ω/GND
Rx Data Output	Single-end output level: 0.10 Vp-p (min.), 1.0 Vp-p (max.) Output waveform: NRZ Connector: SMA connector, 50 Ω/GND
Laser Safety	IEC60825-1: 2007: CLASS 1 21CFR1040.10*

\*: All laser sources of this plug-in unit are classified as Class 1 according to IEC 60825-1 (2007). All laser sources comply with 21CFR 1040.10 except for deviations pursuant to Laser Notice No.50, dated 2007-June-24. The following descriptive labels are affixed to the product.

**CERTIFICATION LABEL**  
THIS PRODUCT CONFORMS TO  
ALL APPLICABLE STANDARDS  
UNDER 21 CFR 1040.10



## Full Rate Clock Output (Option-052)

Operation Frequency	The MP2100A/01A-052 supports output at the following bit rates.  With MP2100A/MP2101A-090 8.0 GHz to 12.5 GHz (1/1 rate) 4.0 GHz to 6.25 GHz (1/2 rate) 2.0 GHz to 3.125 GHz (1/4 rate) 1.0 GHz to 1.5625 GHz (1/8 rate)  Without MP2100A/MP2101A-090 8.5 GHz to 11.32 GHz (1/1 rate) 4.25 GHz to 5.66 GHz (1/2 rate) 2.125 GHz to 2.83 GHz (1/4 rate) 1.0625 GHz to 1.415 GHz (1/8 rate)  No clock is output when operating at the 1/16, 1/32, and 1/64 rates.
No. of Output Ports	1 (Single end)
Amplitude	300 mVp-p to 750 mVp-p
Duty	50±15%
Tr/Tf	30 ps (20 to 80%) (typ.)
Jitter (RMS)	2 ps rms (typ.) (10 GHz, Sync. Clock 1/8) 2 ps rms (typ.) (12.5 GHz, Sync. Clock 1/8, With MP2100A/MP2101A-090)
Connector	SMA connector
Termination	50 Ω/AC coupled
Reference Channel	Clock output synchronization target Ch1 PPG, ED: 1/1 rate, 1/2 rate operation selectable Ch2 PPG: With MP2100A-005 or MP2101A-012 ED: With MP2100A-005 or MP2101A-012 and 1/1 rate or 1/2 rate
Alarm	PLL Unlock Detect Function

## ED High-sensitivity Output (Option-091)

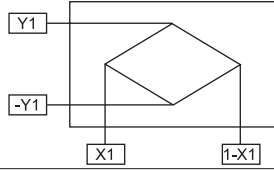
Jitter Standard	Standardized jitter tolerance value per bit rate
Total Jitter: TJ [UI]	10.3125 Gbps: 0.65 4.25 Gbps: 0.325 2.125 Gbps: 0.325
Deterministic Jitter	10.3125 Gbps: 0.45 4.25 Gbps: 0.225 2.125 Gbps: 0.225
SJ (d-d) [UI] (4 MHz)	10.3125 Gbps: 0.22 4.25 Gbps: 0.11 2.125 Gbps: 0.11
Eye Mask Standard	Standardized input Eye mask per bit rate 
Y1: [mV]	MP2100A: Ch1 ED 10.3125 Gbps: 50 4.25 Gbps: 50 2.125 Gbps: 50  MP2100A: Ch2 ED 10.3125 Gbps: 25 4.25 Gbps: 25 2.125 Gbps: 25  MP2101A: Ch1 ED, Ch2 ED 10.3125 Gbps: 25 4.25 Gbps: 25 2.125 Gbps: 25
X1: [UI]	10.3125 Gbps: 0.325 4.25 Gbps: 0.1625 2.125 Gbps: 0.1625

# Ordering Information

Please specify the model/order number, name and quantity when ordering.  
The names listed in the chart below are Order Names. The actual name of the item may differ from the Order Name.

## MP2100A BERTWave

Model/Order No.	Name
MP2100A	<b>-Main frame-</b> BERTWave
MX210000A	<b>-Standard accessories-</b> Power Cord: 1 BERTWave Control Software (CD-ROM, Operation manual): 1
MP2100A-001	<b>-Option-</b> Dual Electrical Receiver
MP2100A-003	Optical/Single-ended Electrical Receiver*1
MP2100A-005	Extended PPG/ED Channel
MP2100A-007	1ch Electrical BERT and Optical/Single-ended Electrical Scope*2
MP2100A-030	GPIO
MP2100A-037	FC Connector
MP2100A-038	ST Connector
MP2100A-039	DIN47256 Connector
MP2100A-040	SC Connector
MP2100A-050	XFP Slot
MP2100A-051	SFP+ Slot
MP2100A-052	Full Rate Clock Output
MP2100A-055	Clock Recovery for Eye/Pulse Scope
MP2100A-056	Low Pass Filter Bank (8.5G/10G/10.7G)
MP2100A-057	Low Pass Filter Bank (2G/4G/8.5G/10G)
MP2100A-061	1 High Bit Rate Filter
MP2100A-062	2 High Bit Rate Filter Bank
MP2100A-063	3 to 4 High Bit Rate Filter Bank
MP2100A-064	1 to 2 Low Bit Rate Filter Bank
MP2100A-065	3 to 4 Low Bit Rate Filter Bank
MP2100A-066	1 High Bit Rate/1 to 2 Low Bit Rate Filter Bank
MP2100A-067	1 to 2 High Bit Rate/3 to 4 Low Bit Rate Filter Bank
MP2100A-068	2 to 3 High Bit Rate/1 to 2 Low Bit Rate Filter Bank
MP2100A-069	3 High Bit Rate/3 Low Bit Rate Filter Bank
MP2100A-070	LPF for 156M (L)
MP2100A-071	LPF for 622M (L)
MP2100A-072	LPF for 1.0G (L)
MP2100A-073	LPF for 1.2G (L)
MP2100A-076	LPF for 2.1G (H)
MP2100A-077	LPF for 2.5G (H)
MP2100A-078	LPF for 2.6G (H)
MP2100A-079	LPF for 3.1G (H)
MP2100A-080	LPF for 4.2G (H)
MP2100A-081	LPF for 5.0G (H)
MP2100A-082	LPF for 6.2G (H)
MP2100A-083	LPF for 8.5G (H)
MP2100A-084	LPF for 9.9G to 10.3G (H)*1
MP2100A-085	LPF for 10.5G to 11.3G (H)
MP2100A-086	LPF for Multi 10G (H)*3
MP2100A-090	Bit Rate Extension for PPG/ED
MP2100A-091	ED High Sensitivity
MP2100A-107	1ch Electrical BERT and Optical/Single-ended Scope Retrofit*4, 5
MP2100A-130	GPIO Retrofit (Upgrade option to original order)
MP2100A-152	Full Rate Clock Output Retrofit
MP2100A-176	LPF for 2.1G (H) Retrofit
MP2100A-177	LPF for 2.5G (H) Retrofit
MP2100A-178	LPF for 2.6G (H) Retrofit
MP2100A-179	LPF for 3.1G (H) Retrofit
MP2100A-180	LPF for 4.2G (H) Retrofit
MP2100A-181	LPF for 5.0G (H) Retrofit
MP2100A-182	LPF for 6.2G (H) Retrofit
MP2100A-183	LPF for 8.5G (H) Retrofit
MP2100A-184	LPF for 9.9G to 10.3G (H) Retrofit
MP2100A-185	LPF for 10.5G to 11.3G (H) Retrofit
MP2100A-186	LPF for Multi 10G (H) Retrofit*6
MP2100A-191	ED High Sensitivity Retrofit

Model/Order No.	Name
J1137	<b>-Standard accessories (MP2100A-001)-</b> Terminator: 2
J1341A	Open (Coaxial connector cover): 5
J1359A	Coaxial Adaptor (K-P · K-J, SMA compatible): 2
J1137	<b>-Standard accessories (MP2100A-003)-</b> Terminator: 2
J1341A	Open (Coaxial connector cover): 4
J1359A	Coaxial Adaptor (K-P · K-J, SMA compatible): 1
J1137	<b>-Standard accessories (MP2100A-005)-</b> Terminator: 2
J1341A	Open (Coaxial connector cover): 2
J1341A	<b>-Standard accessories (MP2100A-050)-</b> Open (Coaxial connector cover): 2
J1341A	<b>-Standard accessories (MP2100A-051)-</b> Open (Coaxial connector cover): 2
J1341A	<b>-Standard accessories (MP2100A-055)-</b> Open (Coaxial connector cover): 1
MP2100A-ES310	<b>-Maintenance service-</b> Three Years Extended Warranty Service
MP2100A-ES510	Five Years Extended Warranty Service

## MP2101A BERTWave PE

Model/Order No.	Name
MP2101A	<b>-Main frame-</b> BERTWave PE
MX210000A	<b>-Standard accessories-</b> Power Cord: 1 BERTWave Control Software (CD-ROM, Operation manual): 1
MP2101A-011	<b>-Option-</b> 1CH PPG/ED
MP2101A-012	2CH PPG/ED
MP2101A-030	GPIO
MP2101A-050	XFP Slot
MP2101A-051	SFP+ Slot
MP2101A-052	Full Rate Clock Output
MP2101A-090	Bit Rate Extension for PPG/ED
MP2101A-091	ED High Sensitivity
MP2101A-130	GPIO Retrofit (Upgrade option to original order)
MP2101A-152	Full Rate Clock Output Retrofit
MP2101A-191	ED High Sensitivity Retrofit
J1137	<b>-Standard accessories (MP2101A-011)-</b> Terminator: 2
J1341A	Open (Coaxial connector cover): 4
J1137	<b>-Standard accessories (MP2101A-012)-</b> Terminator: 4
J1341A	Open (Coaxial connector cover): 6
J1341A	<b>-Standard accessories (MP2101A-050)-</b> Open (Coaxial connector cover): 2
J1341A	<b>-Standard accessories (MP2101A-051)-</b> Open (Coaxial connector cover): 2
MP2101A-ES310	<b>-Maintenance service-</b> Three Years Extended Warranty Service
MP2101A-ES510	Five Years Extended Warranty Service

## MP2102A BERTWave SS

Model/Order No.	Name
MP2102A	<b>-Main frame-</b> BERTWave SS
	<b>-Standard accessories-</b>
MX210000A	Power Cord: 1 BERTWave Control Software (CD-ROM, Operation manual): 1
	<b>-Option-</b>
MP2102A-021	Dual Electrical Receiver
MP2102A-023	Optical/Single-ended Electrical Receiver
MP2102A-030	GPIO
MP2102A-037	FC Connector
MP2102A-038	ST Connector
MP2102A-039	DIN 47256 Connector
MP2102A-040	SC Connector
MP2102A-055	Clock Recovery
MP2102A-061	1 High Bit Rate Filter
MP2102A-062	2 High Bit Rate Filter Bank
MP2102A-063	3 to 4 High Bit Rate Filter Bank
MP2102A-064	1 to 2 Low Bit Rate Filter Bank
MP2102A-065	3 to 4 Low Bit Rate Filter Bank
MP2102A-066	1 High Bit Rate/1 to 2 Low Bit Rate Filter Bank
MP2102A-067	1 to 2 High Bit Rate/3 to 4 Low Bit Rate Filter Bank
MP2102A-068	2 to 3 High Bit Rate/1 to 2 Low Bit Rate Filter Bank
MP2102A-069	3 High Bit Rate/3 Low Bit Rate Filter Bank
MP2102A-070	LPF for 156M (L)
MP2102A-071	LPF for 622M (L)
MP2102A-072	LPF for 1.0G (L)
MP2102A-073	LPF for 1.2G (L)
MP2102A-076	LPF for 2.1G (H)
MP2102A-077	LPF for 2.5G (H)
MP2102A-078	LPF for 2.6G (H)
MP2102A-079	LPF for 3.1G (H)
MP2102A-080	LPF for 4.2G (H)
MP2102A-081	LPF for 5.0G (H)
MP2102A-082	LPF for 6.2G (H)
MP2102A-083	LPF for 8.5G (H)
MP2102A-084	LPF for 9.9G to 10.3G (H)*1
MP2102A-085	LPF for 10.5G to 11.3G (H)
MP2102A-086	LPF for Multi 10G (H)*3
MP2102A-130	GPIO Retrofit (Upgrade option to original order)
MP2102A-176	LPF for 2.1G (H) Retrofit
MP2102A-177	LPF for 2.5G (H) Retrofit
MP2102A-178	LPF for 2.6G (H) Retrofit
MP2102A-179	LPF for 3.1G (H) Retrofit
MP2102A-180	LPF for 4.2G (H) Retrofit
MP2102A-181	LPF for 5.0G (H) Retrofit
MP2102A-182	LPF for 6.2G (H) Retrofit
MP2102A-183	LPF for 8.5G (H) Retrofit
MP2102A-184	LPF for 9.9G to 10.3G (H) Retrofit
MP2102A-185	LPF for 10.5G to 11.3G (H) Retrofit
MP2102A-186	LPF for Multi 10G (H) Retrofit**6
J1341A	<b>-Standard accessories (MP2102A-021)-</b> Open (Coaxial connector cover): 3
J1359A	Coaxial Adaptor (K-P · K-J, SMA compatible): 2
J1341A	<b>-Standard accessories (MP2102A-023)-</b> Open (Coaxial connector cover): 2
J1359A	Coaxial Adaptor (K-P · K-J, SMA compatible): 1
J1341A	<b>-Standard accessories (MP2102A-055)-</b> Open (Coaxial connector cover): 2
	<b>-Maintenance service-</b>
MP2102A-ES310	Three Years Extended Warranty Service
MP2102A-ES510	Five Years Extended Warranty Service

## Optional Accessories

Model/Order No.	Name
J1137	Terminator
J1341A	Open (Coaxial connector cover)
J1359A	Coaxial Adaptor (K-P · K-J, SMA compatible)
J1349A	Coaxial Cable 0.3 m
J1342A	Coaxial Cable 0.8 m
J1343A	Coaxial Cable 1 m
G0238A	SFP+ SR 850 nm
G0239A	SFP+ LR 1310 nm
G0174A	850 nm XFP Module (9.95 to 11.10 Gbit/s)
G0194A	1310 nm XFP Module
G0195A	1550 nm XFP Module
G0177A	850 nm SFP Module (1.062 to 4.25 Gbit/s)
G0178A	1310 nm SFP Module (0.155 to 2.67 Gbit/s)
G0179A	1550 nm SFP Module (0.155 to 2.67 Gbit/s)
J1344A	LC/PC-LC/PC-1M-SM
J1139A	FC · PC-LC · PC-1M-SM
J1345A	SC/PC-LC/PC-1M-SM
J1346A	LC/PC-LC/PC-1M-GI (62.5/125)
J1347A	FC/PC-LC/PC-1M-GI (62.5/125)
J1348A	SC/PC-LC/PC-1M-GI (62.5/125)
J1510A	Pick OFF Tee
B0639A	Carrying Case
W3349AE	MP2100A/MP2101A/MP2102A Operation Manual (Operation)
W3350AE	MP2100A/MP2101A/MP2102A Operation Manual (Remote Control, SCPI)
W3354AE	MP2100A/MP2101A/MP2102A Operation Manual (Remote Control, Native)
G0301A	External CDR Board (<2.667G)
J1512A	7.5G Passive Probe Set
B0650A	Rack Mount Kit

## Software

Model/Order No.	Name
MX210001A	Jitter Analysis Software
MX210002A	Transmission Analysis Software

- \*1: Build to Order.
- \*2: Does not support optical BER measurements. Does not support Clock Recovery function of optical signal.
- \*3: Cannot be used with Option-084.
- \*4: Retrofitting is not supported the optical signal clock recovery function when the MP2100A-055 is installed.
- \*5: Retrofitting is possible only for the MP2100A-003 configuration. It is not supported for the MP2100A-001 configuration.
- \*6: When retrofitting to configurations including the Option-084, the Option-084 must be removed and replaced by either the Option-086.

• **United States**

**Anritsu Company**

1155 East Collins Blvd., Suite 100, Richardson,  
TX 75081, U.S.A.  
Toll Free: 1-800-267-4878  
Phone: +1-972-644-1777  
Fax: +1-972-671-1877

• **Canada**

**Anritsu Electronics Ltd.**

700 Silver Seven Road, Suite 120, Kanata,  
Ontario K2V 1C3, Canada  
Phone: +1-613-591-2003  
Fax: +1-613-591-1006

• **Brazil**

**Anritsu Eletrônica Ltda.**

Praça Amadeu Amaral, 27 - 1 Andar  
01327-010 - Bela Vista - São Paulo - SP - Brazil  
Phone: +55-11-3283-2511  
Fax: +55-11-3288-6940

• **Mexico**

**Anritsu Company, S.A. de C.V.**

Av. Ejército Nacional No. 579 Piso 9, Col. Granada  
11520 México, D.F., México  
Phone: +52-55-1101-2370  
Fax: +52-55-5254-3147

• **United Kingdom**

**Anritsu EMEA Ltd.**

200 Capability Green, Luton, Bedfordshire, LU1 3LU, U.K.  
Phone: +44-1582-433200  
Fax: +44-1582-731303

• **France**

**Anritsu S.A.**

12 avenue du Québec, Bâtiment Iris 1- Silic 612,  
91140 VILLEBON SUR YVETTE, France  
Phone: +33-1-60-92-15-50  
Fax: +33-1-64-46-10-65

• **Germany**

**Anritsu GmbH**

Nemetschek Haus, Konrad-Zuse-Platz 1  
81829 München, Germany  
Phone: +49-89-442308-0  
Fax: +49-89-442308-55

• **Italy**

**Anritsu S.r.l.**

Via Elio Vittorini 129, 00144 Roma, Italy  
Phone: +39-6-509-9711  
Fax: +39-6-502-2425

• **Sweden**

**Anritsu AB**

Borgarfjordsgatan 13A, 164 40 KISTA, Sweden  
Phone: +46-8-534-707-00  
Fax: +46-8-534-707-30

• **Finland**

**Anritsu AB**

Teknobulevardi 3-5, FI-01530 VANTAA, Finland  
Phone: +358-20-741-8100  
Fax: +358-20-741-8111

• **Denmark**

**Anritsu A/S (Service Assurance)**

**Anritsu AB (Test & Measurement)**

Kay Fiskers Plads 9, 2300 Copenhagen S, Denmark  
Phone: +45-7211-2200  
Fax: +45-7211-2210

• **Russia**

**Anritsu EMEA Ltd.**

**Representation Office in Russia**

Tverskaya str. 16/2, bld. 1, 7th floor.

Russia, 125009, Moscow

Phone: +7-495-363-1694

Fax: +7-495-935-8962

• **United Arab Emirates**

**Anritsu EMEA Ltd.**

**Dubai Liaison Office**

P O Box 500413 - Dubai Internet City  
Al Thuraya Building, Tower 1, Suit 701, 7th Floor  
Dubai, United Arab Emirates  
Phone: +971-4-3670352  
Fax: +971-4-3688460

• **India**

**Anritsu India Private Limited**

2nd & 3rd Floor, #837/1, Binnamangla 1st Stage,  
Indiranagar, 100ft Road, Bangalore - 560038, India  
Phone: +91-80-4058-1300  
Fax: +91-80-4058-1301

• **Singapore**

**Anritsu Pte. Ltd.**

60 Alexandra Terrace, #02-08, The Comtech (Lobby A)  
Singapore 118502  
Phone: +65-6282-2400  
Fax: +65-6282-2533

• **P.R. China (Shanghai)**

**Anritsu (China) Co., Ltd.**

Room 1715, Tower A CITY CENTER of Shanghai,  
No.100 Zunyi Road, Chang Ning District,  
Shanghai 200051, P.R. China  
Phone: +86-21-6237-0898  
Fax: +86-21-6237-0899

• **P.R. China (Hong Kong)**

**Anritsu Company Ltd.**

Unit 1006-7, 10/F., Greenfield Tower, Concordia Plaza,  
No. 1 Science Museum Road, Tsim Sha Tsui East,  
Kowloon, Hong Kong, P.R. China  
Phone: +852-2301-4980  
Fax: +852-2301-3545

• **Japan**

**Anritsu Corporation**

8-5, Tamura-cho, Atsugi-shi, Kanagawa, 243-0016 Japan  
Phone: +81-46-296-1221  
Fax: +81-46-296-1238

• **Korea**

**Anritsu Corporation, Ltd.**

502, 5FL H-Square N B/D, 681  
Sampyeong-dong, Bundang-gu, Seongnam-si,  
Gyeonggi-do, 463-400 Korea  
Phone: +82-31-696-7750  
Fax: +82-31-696-7751

• **Australia**

**Anritsu Pty. Ltd.**

Unit 21/270 Ferntree Gully Road, Notting Hill,  
Victoria 3168, Australia  
Phone: +61-3-9558-8177  
Fax: +61-3-9558-8255

• **Taiwan**

**Anritsu Company Inc.**

7F, No. 316, Sec. 1, NeiHu Rd., Taipei 114, Taiwan  
Phone: +886-2-8751-1816  
Fax: +886-2-8751-1817

Please Contact: